

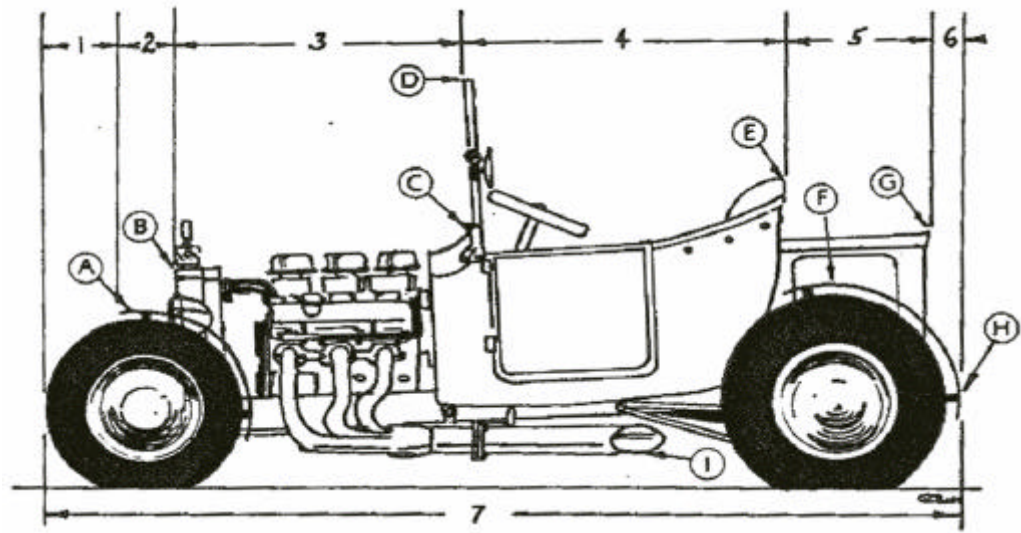

1923 Ford
"T" Bucket
Roadster,
no top,
no rods,
no straps to
windshield



- Lengths - Measured Horizontally**
- # 1 Front of car to front of fender _____
 - # 2 Front of fender to front of hood _____
 - # 3 Front of hood to front of windshield _____
 - # 4 Front of windshield to rear of backrest _____
 - # 5 Rear of backrest to rear of box _____
 - # 6 Rear of box to rear of car _____
 - # 7 Overall length, front to rear _____

- Heights - Measured from Ground**
- HA Height to top of front fender _____
 - HB Height to top of radiator _____
 - HC Height of cowl at windshield _____
 - HD Height at top of windshield _____
 - HE Height at top of backrest _____
 - HF Height at top of rear fenders _____
 - HG Height at rear of box _____
 - HH Height at rear of car _____
 - HI Ground clearance _____

If you have measured correctly, the sum of # 1 through # 6 should equal # 7.

Widths, Measured Side to Side at Points Shown

- WA Width of car at front fender _____
- WB Width across front hood _____
- WC Width across cowl at base of windshield _____
- WD Width of top of windshield _____
- WE Width across seat backrest _____
- WF Width across rear fenders _____
- WG Width of box at rear _____
- WH Width of car at rear _____

Vehicle Information

A photo of the vehicle will help us make the pattern. The photo can be returned if requested.

MAKE _____

MODEL _____

YEAR _____

NAME _____

Daytime phone _____

Date of order _____